

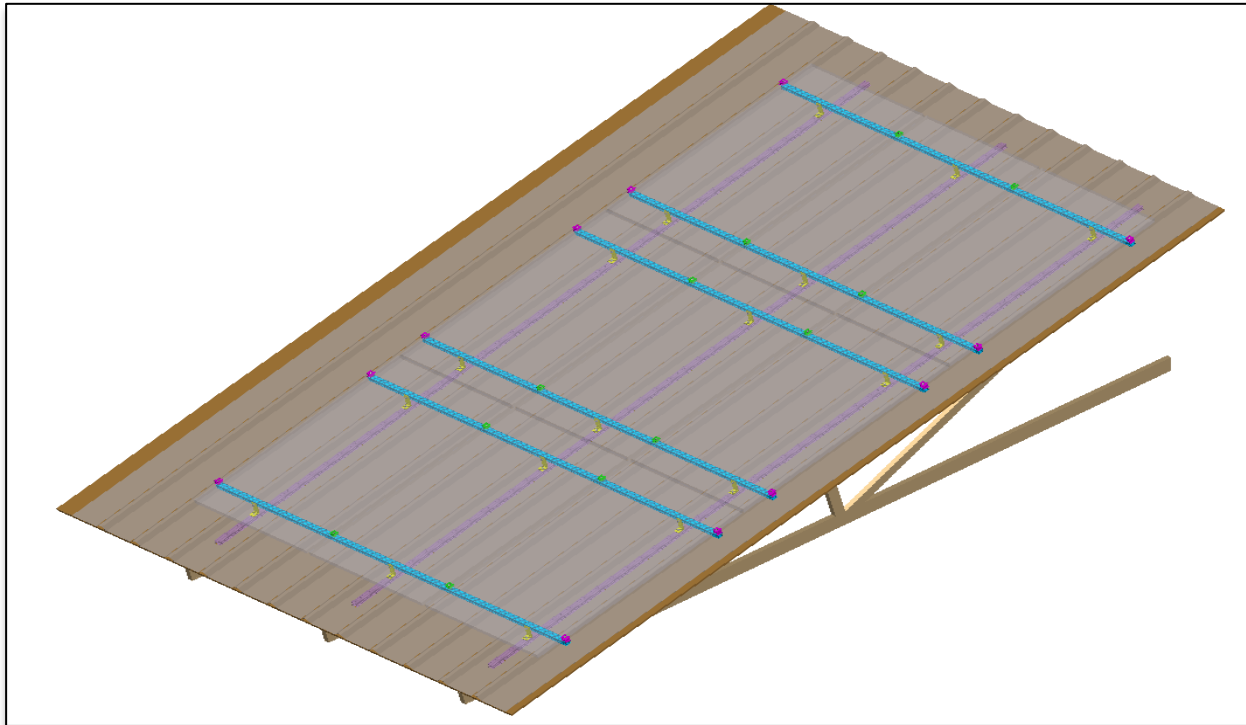

RAIL-BASED FLUSH ON METAL – ROOF CHANNEL

Exposed Fastener Roof



INSTALLATION MANUAL

Table of Contents/Index:

Item	Page(s)
Notes	3
1. Roof Attachment	4
1.1 Components	4
1.2 Advanced Roof Channel Installation	5
1.3 Racking Installation & GA drawing	6
2. Module Clamping	10
3. Rail Splices Installation	10
4. Expansion joint	11
5. Grounding/Bonding	11

NOTES

UL2703 verified compatible modules

Modules chosen for UL2703 grounding/bonding testing were chosen to represent a range of available solar modules. Modules tested were from the following manufacturers:

- LG NeON- Model LGxxxN2W-A5
- Jinko Solar – Model JKMxxxM-72L-V

Grounding/Bonding

- Only grounding/bonding devices listed in this manual have been approved for use with this racking and qualified per UL2703 installation details provided in this document
- This racking system may be used to ground and/or mount a PV module complying with UL 1703 only when the specific modules has been evaluated for grounding and/or mounting in compliance with the included instructions.
- Routine maintenance of a module or panel shall not involve breaking or disturbing the bonding path of the system.

Periodic Inspection

Periodic re-inspection of installed racking components must take place to identify any loose components, loose fasteners or corrosion. Loose or corroded components or fasteners must be replaced immediately.

Fire Rating

****UL1703 FIRE CLASSIFICATION****

This system has achieved a Class A fire rating when installed using UL1703 Fire Classification Type 1 and Type 2 modules under the following conditions:

- Installation must be done in strict accordance to this instruction manual
- The maximum roof slope may be up to 2"/12" or 9.46°

Design Load Rating

System Level Allowable Design Load Rating: 35 psf downward, 20 psf upward, 10 psf down-slope.

Each set of site-specific plans must have system loads evaluated and approved by an appropriate structural engineer. This system is designed to be expandable and is not limited by a maximum number of PV modules. Maximum size of PV modules evaluated was 79.7" x 40.3" (i.e. typical 72-cell) and modules are mounted in portrait. A typical modular rail length is approximately 20' (6m) and could hold up to 6 modules.

Label

After the racking system is fully assembled, a single Marking Label should be applied to the rail at the edge of the array. Note: The sticker label should be placed such that it is visible, but not outward facing.



Sharp Edges and Piercing Module Clamps

Ensure wiring is kept away from any sharp edges that may have resulted from cutting rails etc. Module clamps contain pre-installed bonding nodes which are designed to pierce the module frame when tightened to proper torque.

Site-Specific Engineering Drawings

This manual is to be used in conjunction with any site-specific engineering drawings that have been developed for your specific project.

1. ROOF ATTACHMENT

1.1 Components

Advanced Roof Channel



Advanced L Bracket

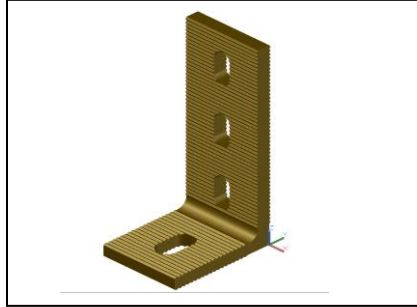

Advanced Rail

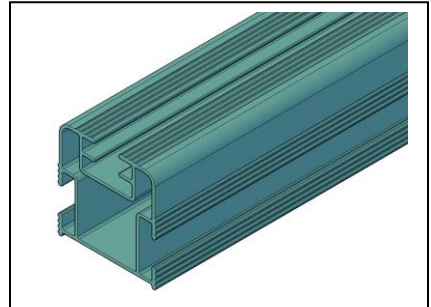

Advanced Rail Splice

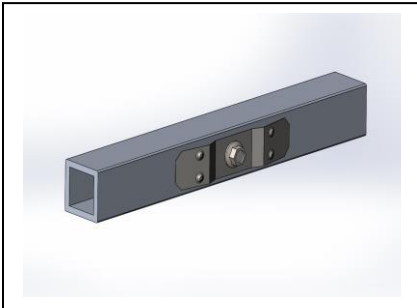

Advanced End Clamp

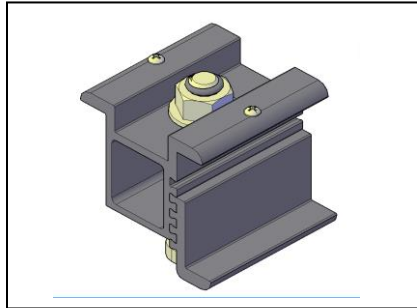

Advanced Mid Clamp

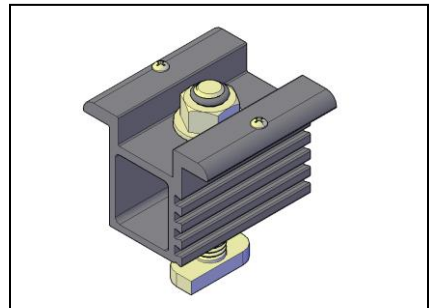

Grounding Lug (SGB-4)

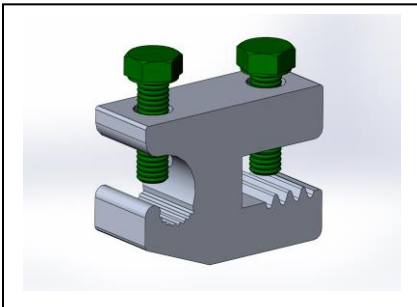

EJOT JT3-2-1/4x2"



T Bolt & Nut

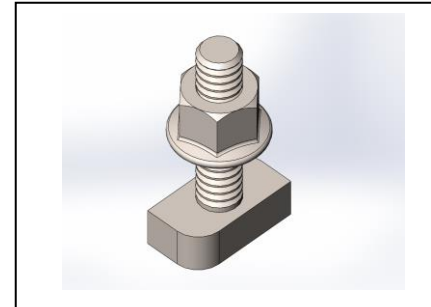

1.2 Advanced Roof Channel Installation

BEFORE YOU BEGIN MAKE SURE YOU HAVE THE CURRENT SITE-SPECIFIC ENGINEERING DRAWINGS AND MODULE LAYOUT DEVELOPED FOR YOUR PROJECT.

- Using measurements from your site-specific Module Layout, locate your starting location on the roof

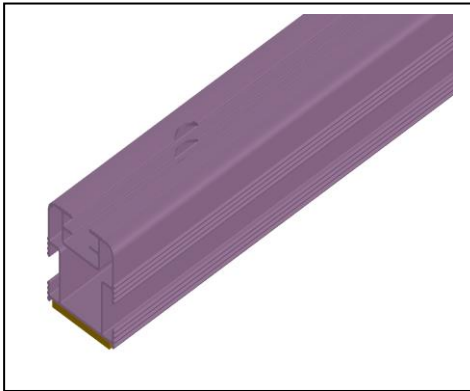

- Advanced Roof Channel come with pre-applied Butyl Tape for creating a weather seal between the bracket and the roof deck.
- A protective film is applied to the underside of the tape. **THIS MUST BE REMOVED** before placing the bracket onto the roof deck.
- Pre-drilled holes through the base of the bracket allow for two EJOT deck screws to be fastened through the bracket, and into the roof.

- Advanced Roof Channel must be position directly over the trusses/rafters or the PE document will not apply to the project (Refer to drawing M-001 or R-001).
- Often the Racking and modules will not be plotted directly over the purlin or strapping locations, therefore the installer must choose the next closest location.
- It is recommended to use a secondary string line to assure Advanced Roof Channel are straight across the roof.

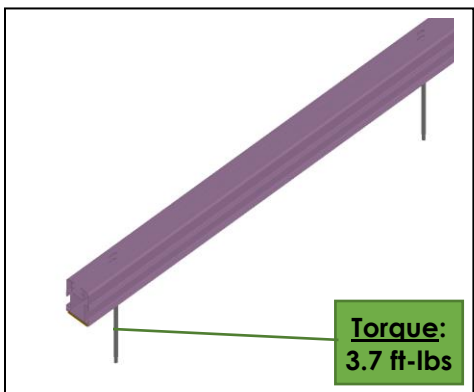

Note:

1. Once the Advanced Roof Channel has been placed down on the roof deck, the butyl tape will hold the bracket in place.
2. The Roof Channel is very difficult to remove once the butyl has made contact with the roof deck. Be sure the bracket is correctly positioned before applying to the roof.
3. 25% compression of the deck is required to ensure a

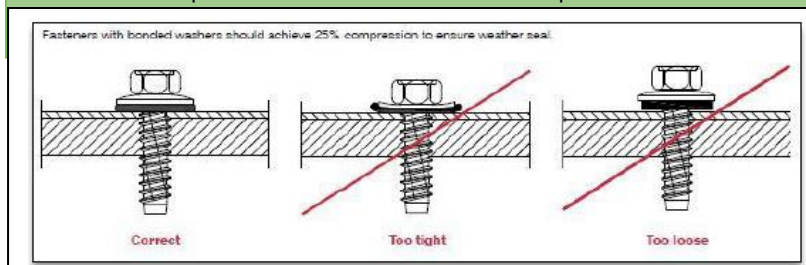

1.3 Racking Installation & GA Drawing

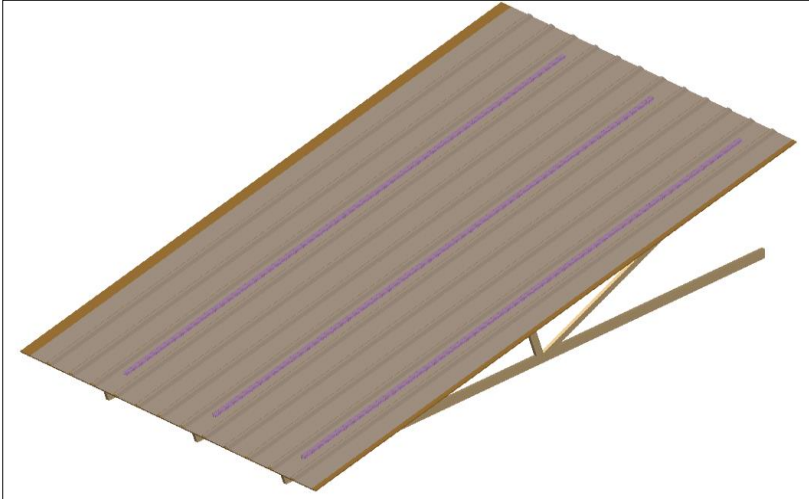

- Space the Roof Channels according to the layout. They should be sitting over the trusses/rafters and on the low flute of the roof deck. Ensure the holes on the roof channel are positioned above the purlins
- Fasten the Roof Channel to every Purlin with the supplied self-drilling EJOT.

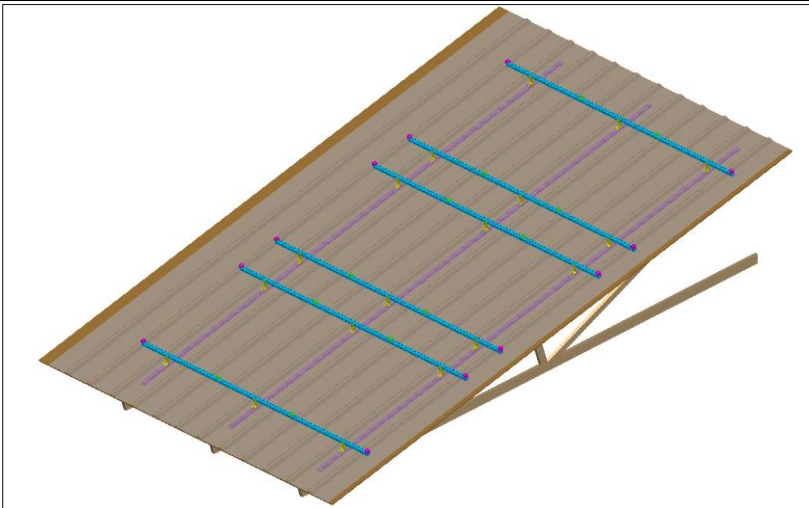

- Use the Top Rail layout to determine the start location and spacing of the L-Feet.
- Attach the L-foot to the bracket using the supplied T-bolt and Nut. T bolt are to be inserted into the upper channel of the bracket.
- Place the top rail on the L-Feet and secure with the pre-assembled T-Bolt

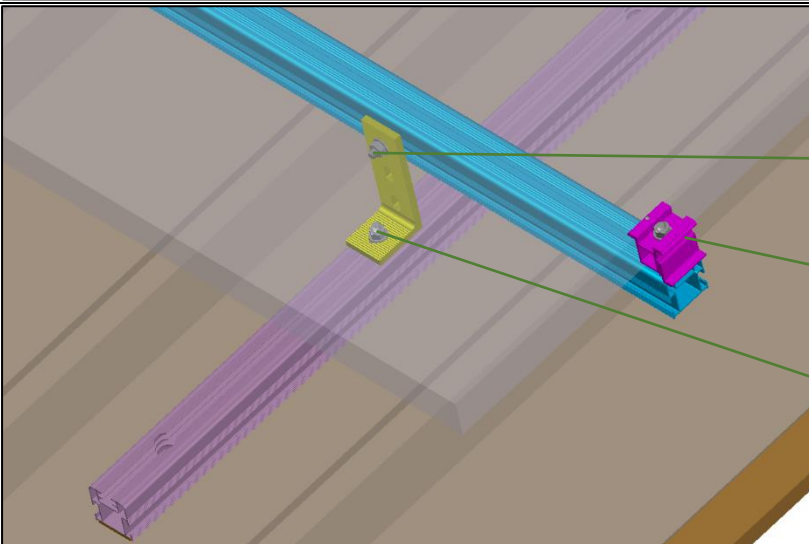

Torque:
13-17 ft-lbs

Torque:
6-8 ft-lbs

Torque:
13-17 ft-lbs

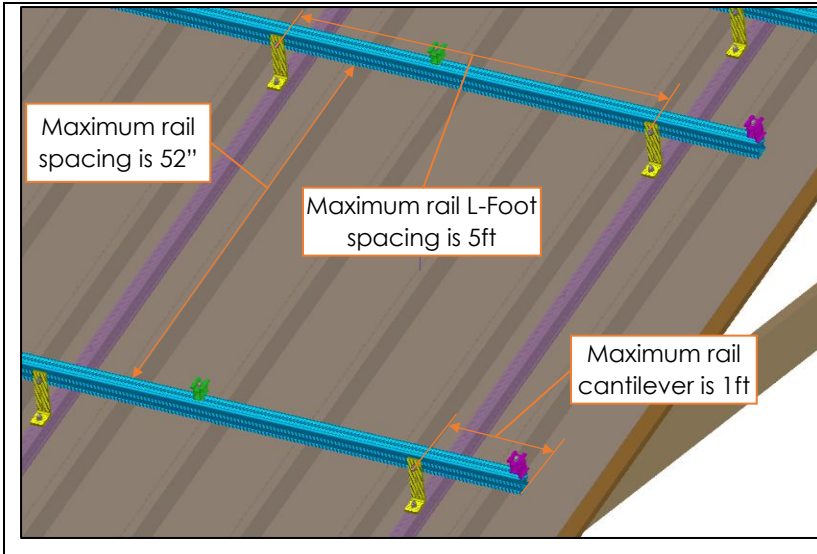

- The system must be installed such as to meet the Max. rail cantilever (1ft), Max. L-foot spacing (5ft) and Max. rail spacing requirements (52").

- **CLAMP NOTE:** if module clamps are loosened for maintenance, the location of the frame piercing pins should be moved to create a new bonding connection.

NOTE: Confirm torque values using only properly calibrated torque wrench.

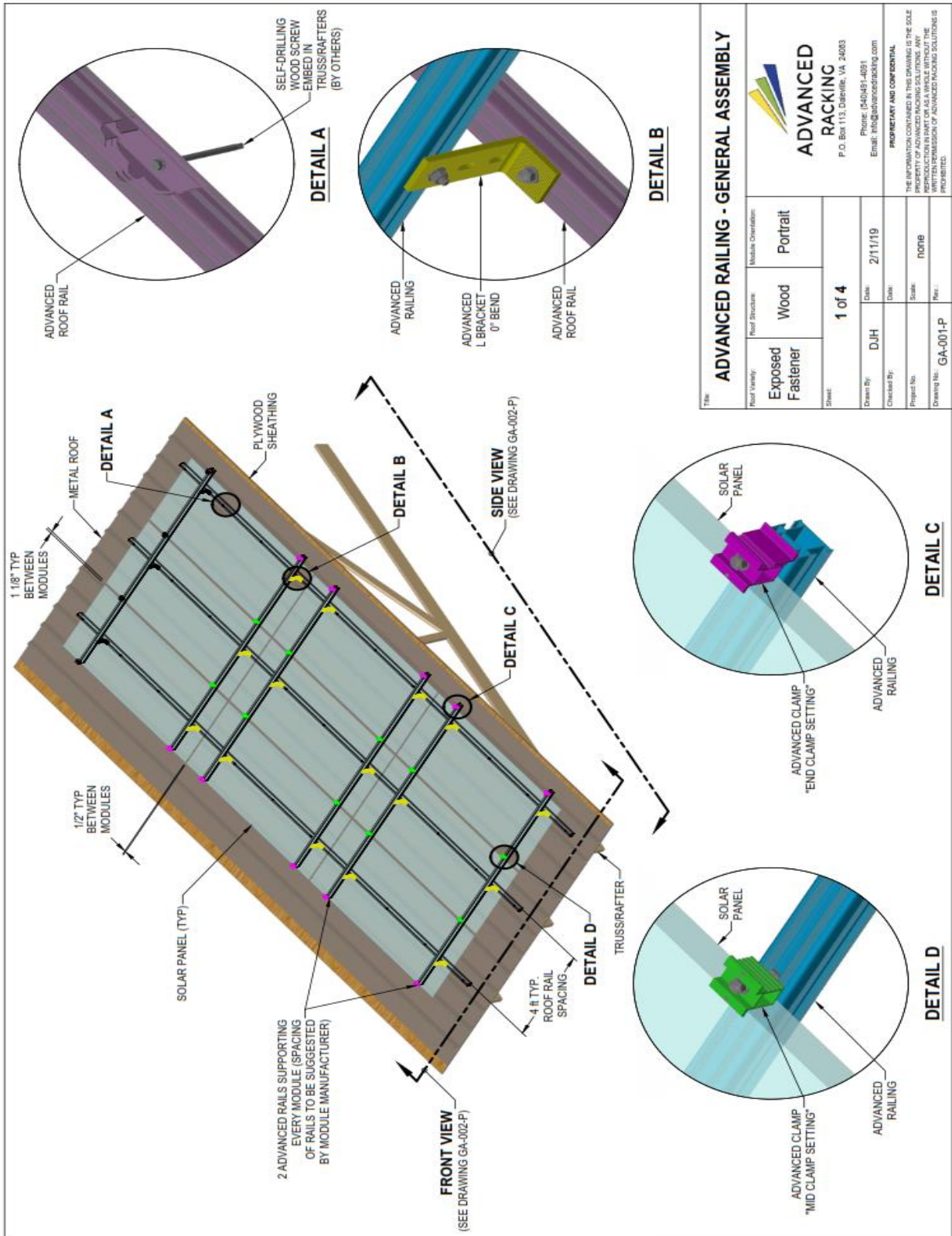

ADVANCED RAILING - GENERAL ASSEMBLY

Product Name: Exposed Fastener	Material: Wood	Module Orientation: Portrait
Sheet: 1 of 4	Drawn By: DJH	Date: 2/11/19
Checked By:	Date:	Scale: N/D/B
Project No.:	Sheet No.:	Rev.:
Drawing No.: GA-001-P		

Phone: (848) 984-4891
Email: info@advancedracking.com
P.O. Box 113, Charlottesville, VA, 24003

ADVANCED RACKING

THE INFORMATION CONTAINED IN THIS DRAWING IS THE SOLE PROPERTY OF ADVANCED RACKING SOLUTIONS. ANY REPRODUCTION IN PART OR AS A WHOLE WITHOUT THE WRITTEN PERMISSION OF ADVANCED RACKING SOLUTIONS IS PROHIBITED.

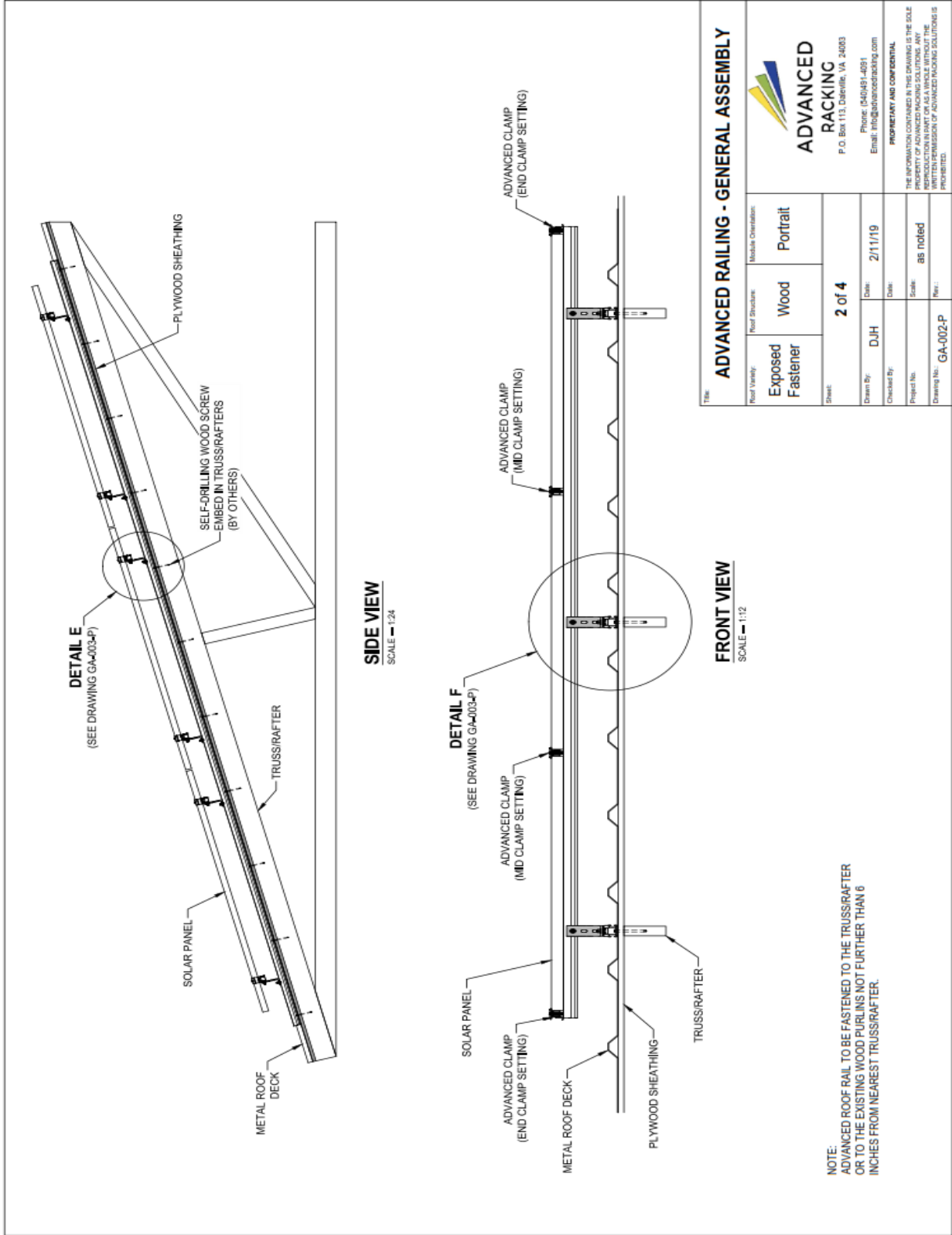

2. Module Clamping

Mid Clamp

1. Place clamp on rail near first module.
Insert T-bolt inside the **TOP SLOT of the rail**.
2. Slide next module. Torque bolt to 6-8 ft-lbs

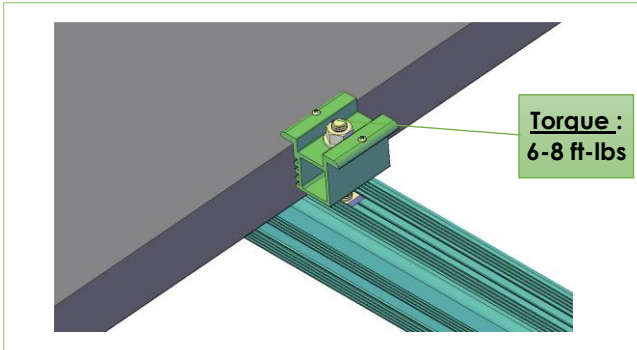

End Clamp

1. Place clamp on rail near end module.
2. For 30 mm thick module only, Mid clamp must be used to replace End Clamp (See figure below).
Torque bolt to 6-8 ft-lbs

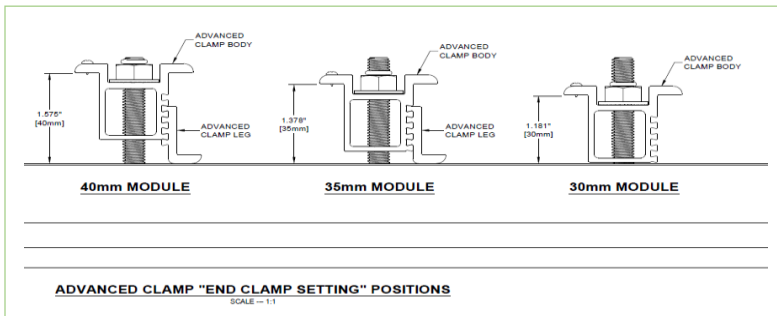
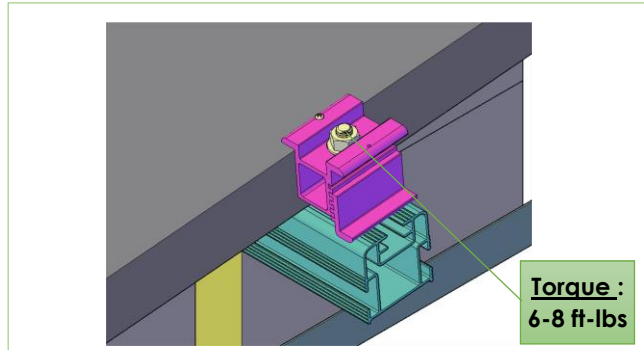

For 40mm, 35mm and 30mm thick modules, use corresponding end clamp configuration as shown on the figure beside.

Note: T Bolts are inserted into the **TOP SLOT of the rail**.

3. Rail Splice Installation

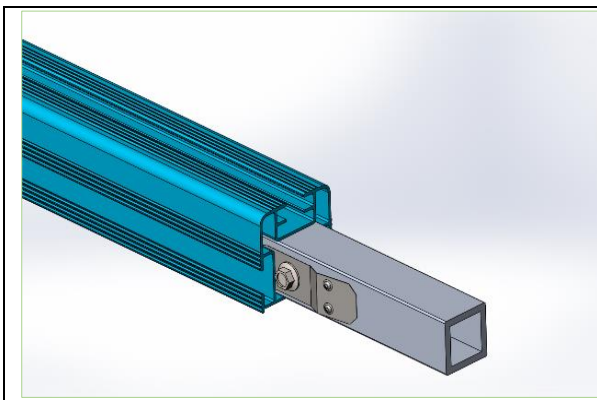

- Join rails by inserting splice bar into first rail, then sliding second rail over splice. The integrated bonding washer bonds the two pieces of rail. No braided jumper is necessary.
- Splice bars must be inserted into the cavity of the Advanced rail before you can complete the installation to the L-Foot
- Make sure splice bar locations do not land directly over an L-Foot. Splice bars should be roughly 1/3 distance between L-Foot locations

4. Expansion Joints

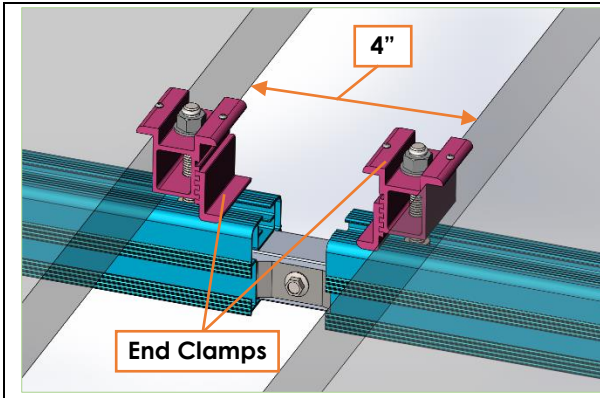

- Expansion joints are required to minimize stresses to the racking, modules and the roof due to thermal expansion.
- Adding an expansion joint consists of ending a row of modules using end clamps, adding rail splices, then beginning the row again using end clamps on the adjacent rail.
- Expansion joints are typically added every 27 modules, though it is recommended to follow the rail layout drawings provided.

5. Grounding / Bonding

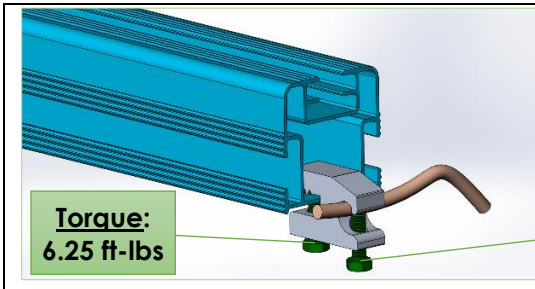

- As per the diagram beside, use SGB-4 to bond one rail per row of modules using #6 copper wire. System grounding must be in accordance with the National Electrical Code, ANSI/NFPA 70.

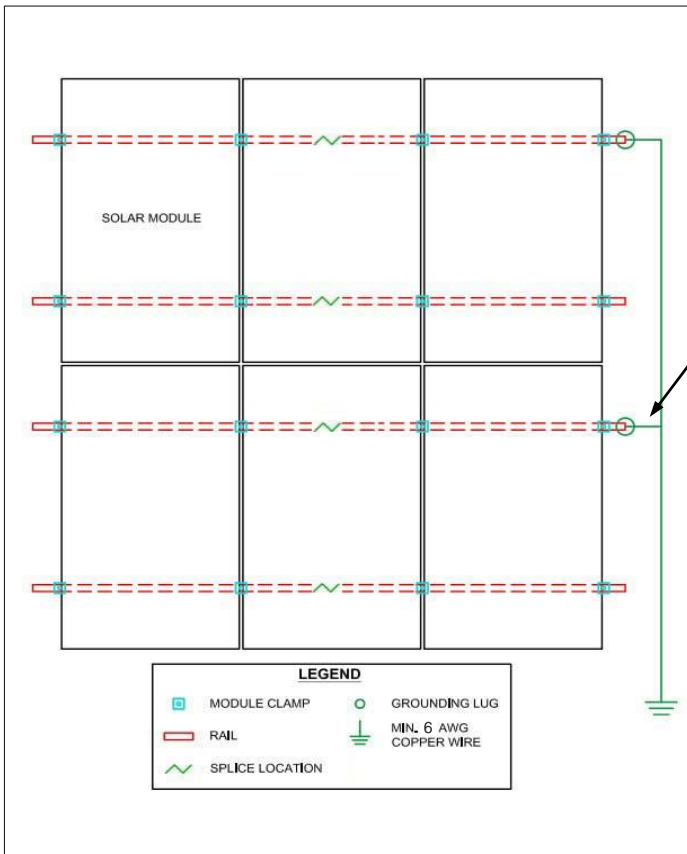

Affix UL2703 label to racking near final ground lug (i.e. last ground lug before ground wire leaves array for combiner or inverter).

NOTE: Module clamps have piercing pins achieving an electrical bonding between the module and the advanced rail.

NOTE: ISOLATE COPPER FROM ALUMINUM CONTACT TO PREVENT CORROSION.

NOTE: AFFIX UL2703 LABEL TO THE RACKING IN A VISIBLE LOCATION NEAR THE GROUND LUG AT FINAL BONDING LOCATION.